

POP & LOCK[®]

Installation Instructions

Cabinet Lock PL5220

Toyota Tacoma 2005 and up

Contents:

Lock Cylinder, Lock Washer
Lock Screw, Lock Cam, Lock Clip
Stiffening Plate, 4 Carriage Bolt,
4 Nuts, Instructions, Warranty Card

Tools Required:

Screw Driver, Power Drill with 5
MM drill bit, 11MM Socket

Tech Support: 1-800-342-5911

For the latest instructions please
visit www.popandlock.net

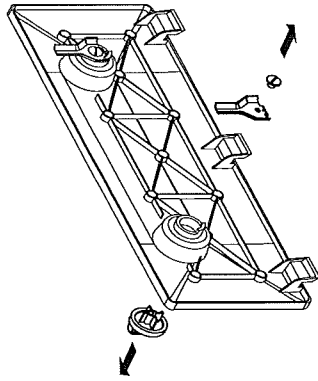

1. UnscREW the Knob and the Cam

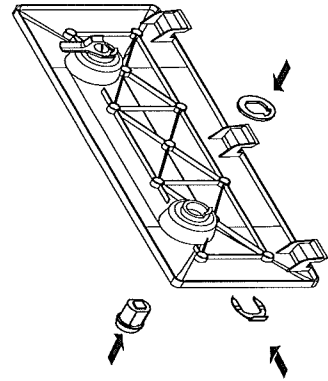

2. Insert the Lock from the front,
the Lock Washer from the rear and
the Lock Clip from the side

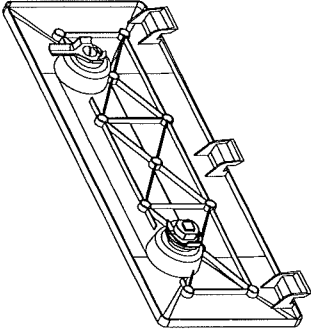

3. Push the Lock Clip in fully to hold
the Lock and Washer in place.

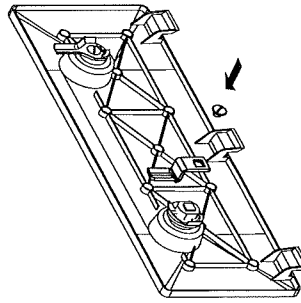

4. Mount the Lock Cam to the Lock.
Turn the key to check the Cam
turns freely. You may have to pull
the Clip slightly for clearance.
Make sure cam turns.

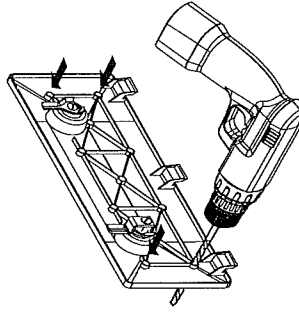

5. Drill four holes through the Cover
using the corner bosses as guides.
IMPORTANT: Don't drill through
the center bosses.

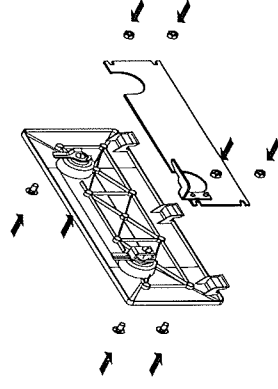

6. Insert the 4 Carriage Bolts from the
front and mount the Stiffening
Plate with the four nuts.

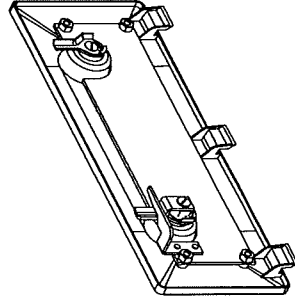

7. Tighten the four Nuts and turn the
key to check for smooth operation.

LIMITED WARRANTY TERMS AND CONDITIONS

- (1) **Installation.** Pop & Lock™, LLC (and Pop & Lock™ Corporation) is not responsible for installing the Pop & Lock™ or for the harm suffered by any person as a result installing it.
- (2) **Warranties.**
- Customer acknowledges that it is unreasonable to believe that any device whatever will prevent a theft in the case of every attempt and that the most that can be expected from a so-called anti-theft or security device is that it will deter many thieves.
 - POP & LOCK™ LLC. (and Pop & Lock™ Corporation) MAKES, AND CUSTOMER RECEIVES, NO WARRANTY, EXPRESSED OR IMPLIED, EXCEPT THE WARRANTIES OF TITLE TO THE POP & LOCK™ AND THEIR MERCHANTABILITY, PARTICULARLY NO WARRANTY OF FITNESS FOR A PARTICULAR USE OR PURPOSE OR AGAINST INFRINGEMENT.**
 - As Customer's only remedy, Pop & Lock™, LLC (and Pop & Lock™ Corporation) will repair or replace, at its option and without charge, any lock that is defective in material or workmanship when received by Customer and is returned to Pop & Lock™ LLC (and Pop & Lock™ Corporation), FOB Pop & Lock™ Corporation's offices, within one (1) year after it's receipt by the Customer. Pop & Lock LLC will ship all replacement, or repaired, Locks to Customer, FOB Pop & Lock™'s shipping point.
 - Factory support is only available for Pop & Lock™ products purchased as new through an Authorized Pop & Lock™ dealer.
Please Note: Pop & Lock™ Products purchased on auction sites such as Ebay, Amazon and Craigslist, to name a few, will not be covered under factory warranty under any circumstance. Pop & Lock™, LLC (and Pop & Lock™ Corporation) is unable to verify whether products sold through Auction Sites are new, used, or refurbished, and as such, Pop & Lock, LLC (and Pop & Lock™ Corporation) is unable to warranty such purchases. Pop & Lock, LLC advises using extreme caution when buying through auction sites as you'll be doing so at your own risk.
- (3) **No Liability.** Pop & Lock™ Corporation is not liable for any loss or damage claimed by Customer or any third person to have been suffered or incurred as a result or, or related to, the Locks purchased under this Agreement, regardless of the circumstances or form of action, except any bodily injury or death for which Pop & Lock™ is liable under products-liability law. Without limiting the generality of the foregoing, in no event will Pop & Lock™ LLC be liable to Customer for any indirect, special, or consequential damages, regardless of the circumstances or the cause of action, particularly not for the value of a vehicle, or any other money damages in the event that a tailgate is stolen either notwithstanding the use of a Pop & Lock™ or when it has been returned for repair or replacement.

END OF TERMS AND CONDITIONS

Please Mail Completed Warranty Form (below) In Self Addressed Envelope To:

POP & LOCK LLC 1271 CONTRACT DRIVE GREEN BAY, WI USA 54304

Additional Install Instructions and answers to technical questions can be found on our website at www.popnlock.net or by calling
Technical Support 1-800-342-5911
Monday – Friday 8am to 5pm CST



POP & LOCK™ LIMITED WARRANTY FORM

Please complete and mail this form to record your warranty with the manufacturer.

NAME _____

ADDRESS _____

CITY _____

STATE _____ ZIP _____

TELEPHONE # _____

EMAIL ADDRESS _____

POP & LOCK™ MODEL _____

VEHICLE YEAR _____

VEHICLE MAKE/MODEL _____

REASON FOR RETURN (continue on other side):



Installation Instructions Tailgate Lock PL5500 Series

**Toyota Tacoma
2005 - UP**

Package Contents: Handle Assembly
Instructions

Tools Required: T30 Torx (Star) Bit/Driver
10mm Wrench

Step 1: Remove the T30 torx (star) screws from the inside of the tailgate that hold the access panel in place. Remove the access panel by lifting the bottom and sliding it out of the top plastic trim piece. You may have to lift the trim piece up away from the tailgate in the middle to allow the access panel down to slide down.

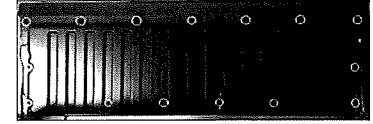

Step 2: Remove the latch rods from the plastic clips (1). Do this by turning the clips off of the rod and lift the rod out of the clip.

-If truck has a back up camera, remove the two 10mm bolts (2) that hold the camera and holder onto the OEM handle.

-Remove the two 10mm bolts (3) that hold the handle into the tailgate. Hold the handle in place to prevent the handle from falling out.

-Push the two plastic tabs of the gasket in towards the handle past the sheet metal and remove the handle from the tailgate.

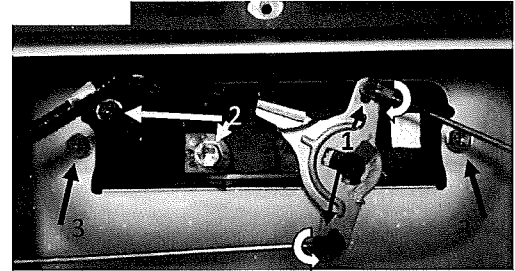

Step 3: * THE LEFT DRIVER'S SIDE LATCH ROD NEEDS TO BE FLIPPED**

END FOR END*** in order to allow for the lock assembly. (The Handle Assembly may work with not flipping the latch rod, but may cause premature failure.) Do this by popping the latch rod out of the black clip, which is located at the center of the rod. Push the rod towards the bottom of the tailgate to pop it out of clip. Next remove the rod from the driver side latch. This latch clip is towards the driver side of the tailgate under the sheet metal inside the tailgate. This clip is the same type as the ones on the handle. Turn the clip off of the rod and lift the rod out of the clip. Flip the rod **end for end** so the bent part of the rod is closer to the driver side latch. The rod will run along the top part of the tailgate as shown in the picture. Insert

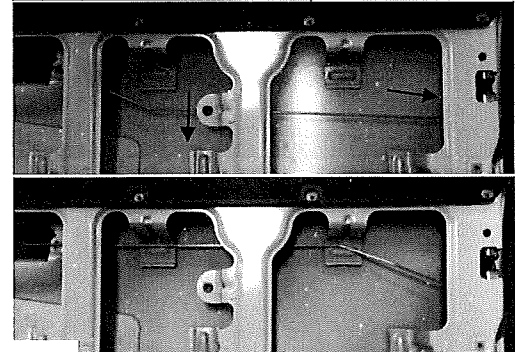

Step 4: Remove the plastic gasket by pulling it off the OEM handle and reinstall it onto the Pop and Lock handle ensuring it is seated on the 3 plastic posts.

-Install the Pop and Lock handle into the tailgate. Start by verifying that the black plastic toggle on the back of the pop and lock is pushed to the unlock position and the metal rod clip plate is rotated fully clockwise (as shown in the bottom picture). *You may have to hold the plate rotated as you install the handle.* Put the bottom of the handle into the tailgate first then rock the top of the handle into the tailgate. The tabs on the gasket should snap past the sheet metal. (Hold the handle in place to prevent the handle from falling out).

-Install the two 10mm bolts that fasten the handle to the tailgate.

-If truck has backup camera, remove the camera cover from the PL5400 by pushing in on the 2 snap tabs and popping the cover off of the handle. Position camera on the handle. If the metal rod from the handle interferes, slide the rod back out of the way. Install the two 10mm bolts to fasten camera.

-Install the rods into the clips and turn the clips till they snap onto the rods.

(Do not install the access panel back onto the truck yet)

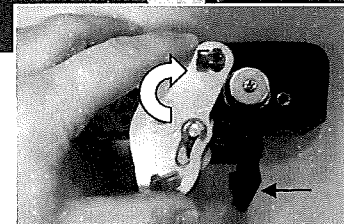
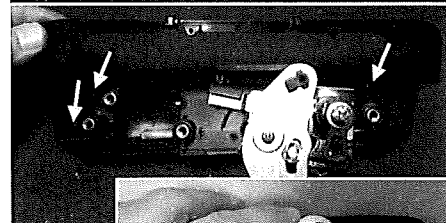
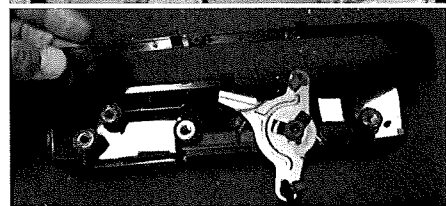

Step 5: - Shut the tailgate. Test the function of the lock. Turn the key clockwise and back to center to lock. Turn the key counter clock wise and back to center to unlock. If everything works reinstall the access panel.

Technical Support:
Call 1-800-342-5911
technicalsupport@popandlock.net

LIMITED WARRANTY TERMS AND CONDITIONS

(1) **Installation.** Pop & Lock™, LLC (and Pop & Lock™ Corporation) is not responsible for installing the Pop & Lock™ or for the harm suffered by any person as a result installing it.

(2) **Warranties.**

- a. Customer acknowledges that it is unreasonable to believe that any device whatever will prevent a theft in the case of every attempt and that the most that can be expected from a so-called anti-theft or security device is that it will deter many thieves.
- b. **POP & LOCK™ LLC. (and Pop & Lock™ Corporation) MAKES, AND CUSTOMER RECEIVES, NO WARRANTY, EXPRESSED OR IMPLIED, EXCEPT THE WARRANTIES OF TITLE TO THE POP & LOCK™ AND THEIR MERCHANTABILITY, PARTICULARLY NO WARRANTY OF FITNESS FOR A PARTICULAR USE OR PURPOSE OR AGAINST INFRINGEMENT.**
- c. As Customer's only remedy, Pop & Lock™, LLC (and Pop & Lock™ Corporation) will repair or replace, at its option and without charge, any lock that is defective in material or workmanship when received by Customer and is returned to Pop & Lock™ LLC (and Pop & Lock™ Corporation), FOB Pop & Lock™ Corporation's offices, within one (1) year after it's receipt by the Customer. Pop & Lock LLC will ship all replacement, or repaired, Locks to Customer, FOB Pop & Lock™'s shipping point.
- d. Factory support is only available for Pop & Lock™ products purchased as new through an Authorized Pop & Lock™ dealer.

Please Note: Pop & Lock™ Products purchased on auction sites such as Amazon, Ebay and Craigslist, to name a few, will not be covered under factory warranty under any circumstance. Pop & Lock™, LLC (and Pop & Lock™ Corporation) is unable to verify whether products sold through Auction Sites are new, used, or refurbished, and as such, Pop & Lock, LLC (and Pop & Lock™ Corporation) is unable to warranty such purchases. Pop & Lock, LLC advises using extreme caution when buying through auction sites as you'll be doing so at your own risk.

(3) **No Liability.** Pop & Lock™ Corporation is not liable for any loss or damage claimed by Customer or any third person to have been suffered or incurred as a result or, or related to, the Locks purchased under this Agreement, regardless of the circumstances or form of action, except any bodily injury or death for which Pop & Lock™ is liable under products-liability law. Without limiting the generality of the foregoing, in no event will Pop & Lock™ LLC be liable to Customer for any indirect, special, or consequential damages, regardless of the circumstances or the cause of action, particularly not for the value of a vehicle, or any other money damages in the event that a tailgate is stolen either notwithstanding the use of a Pop & Lock™ or when it has been returned for repair or replacement.

END OF TERMS AND CONDITIONS

POP & LOCK LLC 1271 CONTRACT DRIVE GREEN BAY, WI USA 54304

Additional Install Instructions and answers to technical questions can be found on our website at www.popandlock.net or by calling

**Technical Support 1-800-342-5911 option 1
Monday – Friday 8:30am to 4:30pm CST**

Pop and Lock's limited warranty expires one (1) year after date of purchase.

Proof of purchase is required for warranty claims. Please submit a scanned copy or electronic image/photo of your receipt through any of the following methods:

- E-mail: technicalsupport@popandlock.net
- Fax: 855-491-5911
- Mail: 1271 Contract Ave, Green Bay, Wisconsin (USA) 54304

Please be sure to include:

- Name, address and phone number
- Model and year of truck
- Model/Part number of the lock
- Brief description of the problem

